

January 1, 2016



***Overhead Winding Drum  
Residential Elevator  
Planning Guide***



P.O. Box 749, 5191 Stump Rd., Plumsteadville, PA 18949 Toll Free: 888-443-2800, Phone: 215-766-3380, Fax: 215-766-3385

# Introduction

---



*This planning guide is intended to provide a general guideline for builders, architects, and homeowners designing for a residential elevator manufactured by Custom Elevator Manufacturing Company. It is recommended that you contact your local authorities governing the installation of residential elevators in your area and follow any regulations that may take precedence over any recommendation listed or detailed in this guide.*

*If you should have any questions or would like to locate a dealer in your area, please call our sales department at 1-888-443-2800.*

## Contents

---

- **Equipment Overview . . . . . 1**
- **Work by Others . . . . . 2**
- **Hoistway Size Requirements . . . . . 3 - 4**
- **Recommended Hoistway Construction Plan . . . . . 5**
- **Recommended Hoistway Construction Elevation . . . . . 6**
- **Control Equipment / Machine Room Plan . . . . . 7**
- **Specifications . . . . . 8 - 9**

# Equipment Overview

## ➤ General:

- Travel up to 50'
- Up to five (5) stops
- Load capacity: 750 lbs (950lbs optional)
- Speed: 40 fpm
- Overhead: 9'-0" minimum
- Pit depth: 8" minimum (10" Recommended)
- 220 volt single phase power supply
- Overhead Winding Drum Drive
  - Elevator Controller can be located up to 50' from the hoistway.
  - 3 HP motor with (VVVF) speed control
  - DC Brake

## ➤ Standard Features:

- Car size: 36" x 48" interior
- 80" interior ceiling height
- No. 4 (brushed) stainless steel hall call and car operating panel
- Brushed Stainless Steel handrail
- Classic cab design
- Accordion gate with vinyl laminate panels
- Two (2) recessed down lights
- White melamine ceiling
- Unfinished plywood floor
- Sill set for 3/4" finished floor
- Digital floor position indicator with car direction arrows
- "Car Here" and "Acknowledge" lights
- Automatic on/off car lighting
- Emergency stop and alarm bell
- Emergency lighting
- Car lighting override switch
- Battery lowering
- Homepark feature
- Manual lowering device
- Telephone in cab
- Microprocessor based control system
- Protection Run Timer
- Machine Limit Switches
- Overspeed Governor
- Approved/Certified Electro-Mechanical Door Locks
- Two year limited parts warranty

## ➤ Optional Features:

- Custom car sizes (Consult Factory)
- 88" interior cab height
- Premier, Signature, and Hampton Series cabs available in variety of finishes and other options
- Accordion cab doors in hardwood, custom stain and lacquer finish, aluminum, and clear or bronze acrylic panels
- Recessed telephone cabinet
- Automatic car door operator
- Polished stainless steel, brushed brass, or polished brass pushbutton faceplate and handrail finishes

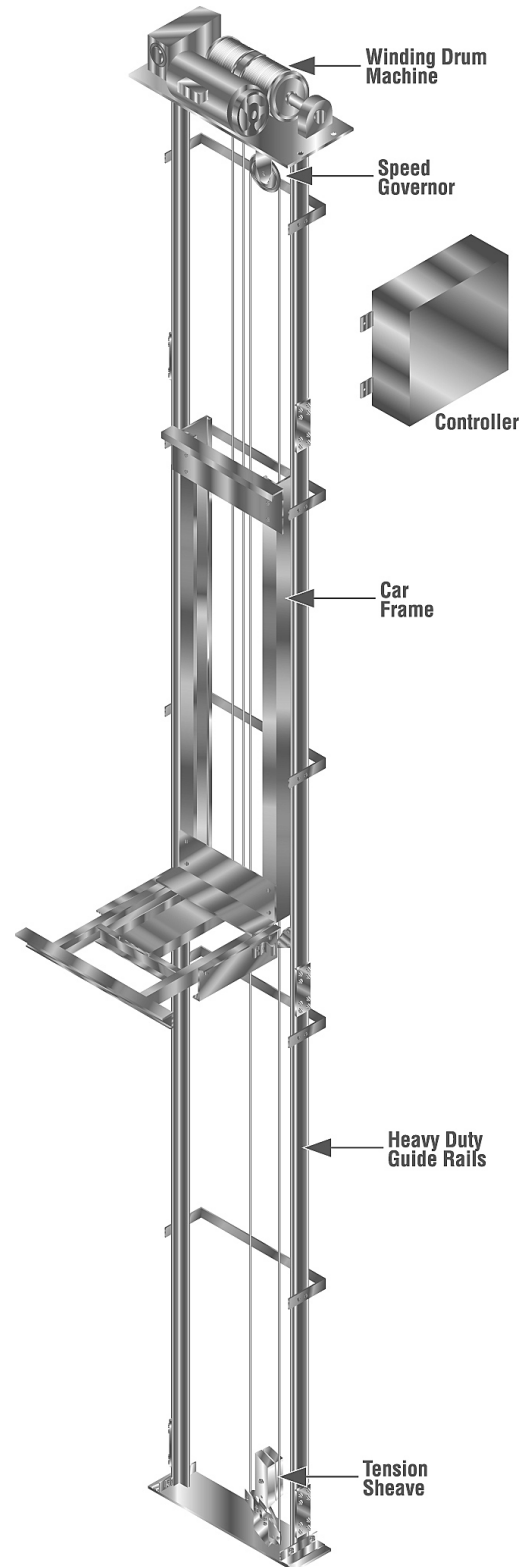

# Work by Others

*Customer, or customer's contractor, shall be responsible, at the customer's expense, for the following prior to the commencement of work by the elevator contractor.*

1. Finished hoistway guaranteed plumb within ½ inch from top to bottom, and conforming to the dimensions indicated on layout drawings provided. All walls and side members must be square and extend from sill to beam above. Inside surface of hoistway must be flush. Interior of hoistway and doors should be finished prior to installation. Hoistway must be constructed in accordance with ASME A17.1 and all state and local building code requirements.
2. Adequate supports shall be provided for fastening rail brackets as indicated on the layout drawings. Supports must withstand rail forces indicated.
3. Where wood frame construction is used, double 2 X 12's spaced as indicated on layout drawings, and extending the full height of the hoistway are recommended.
4. For masonry walls, inserts shall be provided by elevator contractor and installed by the general contractor.
5. Total travel distance from finished bottom floor to finished top floor must be held within 1" of that shown on layout drawings.
6. Overhead clearance: (top floor to underside of hoistway ceiling or obstruction) to be maintained per the layout drawings. If 9'-6" cannot be achieved, contact factory for alternate arrangement.
7. A poured pit conforming to the dimensions indicated on the layout drawings must be provided. The pit must be designed for the impact load indicated and must be guaranteed dry and level from wall to wall.
8. A sump pump and sump pump hole with cover is recommended in the elevator pit where water seepage is encountered. A G.F.I. receptacle is required if a sump pump is furnished. Coordinate location with elevator contractor.
9. A pit light with switch if required by local code.
10. All screens, railings, steps, and ladders as required for legal hoistway.
11. Barricades outside all hoistway openings for protection shall be provided and installed by general contractors.
12. All blockouts for hall buttons must be provided. Location to be coordinated with elevator contractor.
13. Kiln dried, solid core, wood or steel hoistway doors, entrances, sills, and associated framing to be provided and installed by purchaser or general contractor. Door closers or spring-loaded hinges are required. Provide a sill support at each landing that projects into the hoistway as shown. Bottom of support shall be beveled. Sill support to be full width of the hoistway.
14. Distance between hoistway door and sill must not exceed ¾" and clearance between hoistway door and car gate must reject a 4" diameter ball at all points per ANSI/ASME A17.1-2016 Code.
15. All wall patching, painting, and grouting by others.
16. When a separate machine room is required, it shall be built to conform to the layout drawings, N.E.C., ASME A17.1, and all state and local code requirements. It shall have suitable access, a lockable door, a convenience outlet, and light switch. Machine room temperature must be maintained between 60 and 100 degrees Fahrenheit. Relative humidity not to exceed 95%.
17. A 220V, single phase, 30 AMP service, with neutral, to a lockable safety disconnect switch fused with time delay fuses shall be furnished in the machine room in accordance with N.E.C. A normally open electric interlock contact is required in the switch for battery isolation.

Source for single phase 3HP heavy duty switch (or equal) : Square "D" Cat. #H-221N; electric interlock #EIK-031. ITE Cat. #SN-321, electric interlock #SC-3. Cutler Hammer Cat. #DH221NGK; electric interlock #DS200EK1.
18. A 120VAC, single phase, 15 AMP service to a lockable disconnect switch or circuit breaker located in the machine room shall be provided for the cab lighting in accordance with N.E.C.
19. A telephone line to the machine/controller room and tied into the elevator controller as per ASME A17.1 code.
20. Machine room vents if required by local code.
21. Knock-out in walls between the machine / controller room and elevator hoistway for routing electrical lines shall be coordinated with elevator contractor.
22. A lockable self closing machine / governor access door (2'-0" x 2'-0" max.) with electric contact shall be provided in accordance with the layout drawings (when required).

# Hoistway Size Requirements

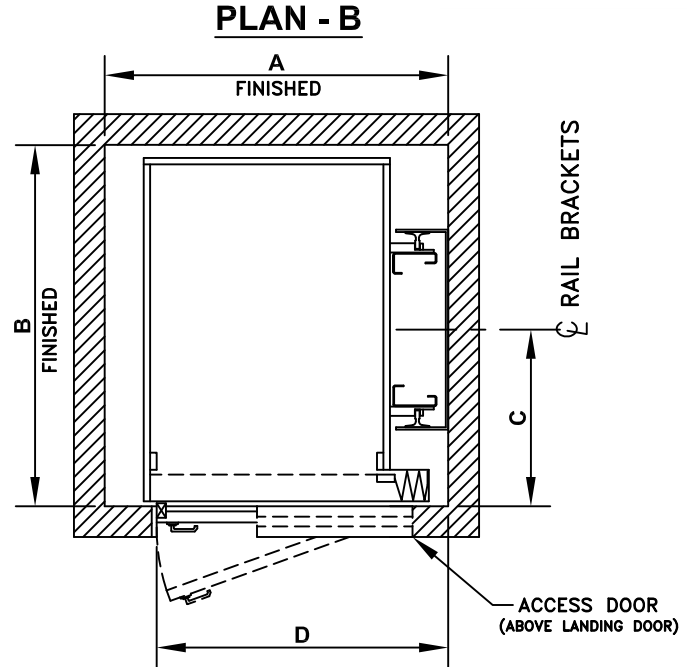
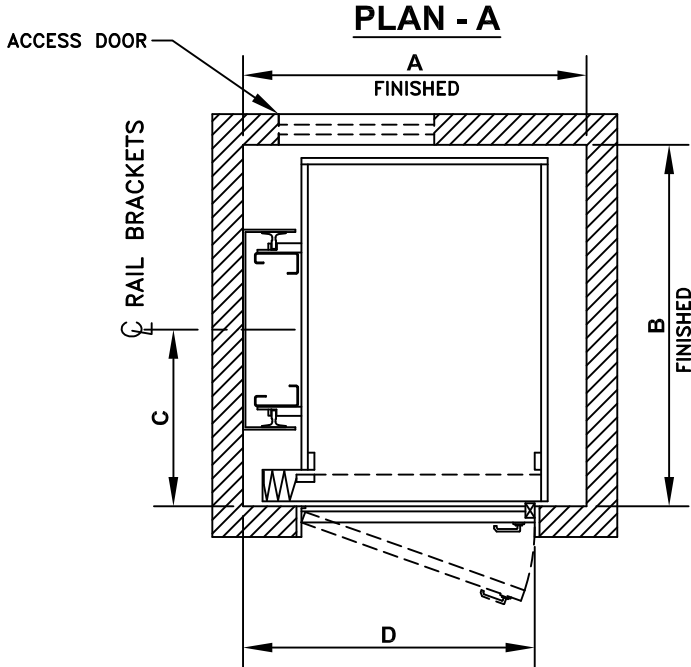

CAPACITY	A	B	C	D
750 LBS	4'-5"	4'-9"	2'-3 1/4"	3'-9"
950 LBS	4'-5"	5'-9"	2'-9 1/4"	3'-9"

CAPACITY	A	B	C	D
750 LBS	4'-5"	4'-9"	2'-3 1/4"	3'-9"
950 LBS	4'-5"	5'-9"	2'-9 1/4"	3'-9"

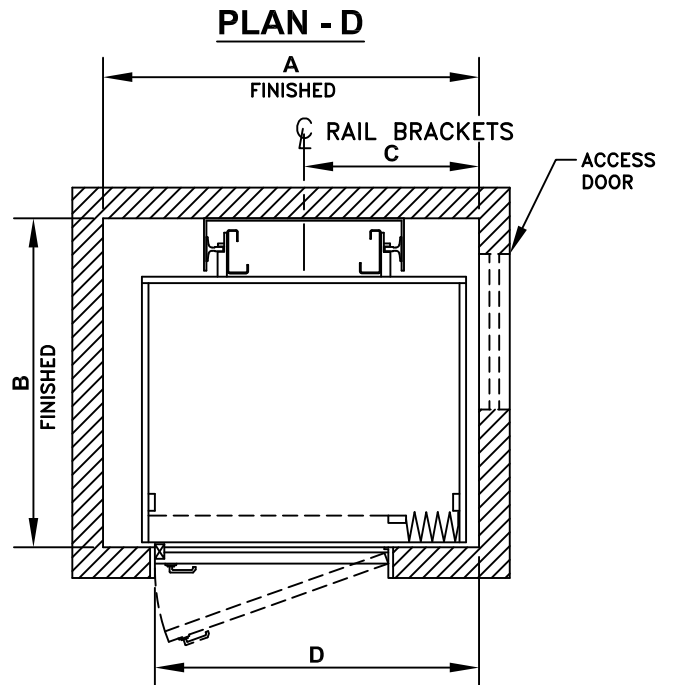
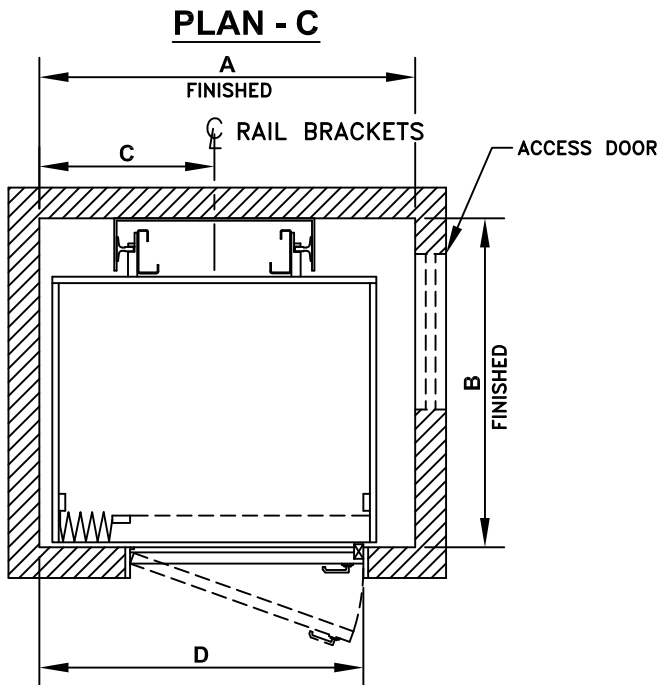

CAPACITY	A	B	C	D
750 LBS	4'-10"	4'-4"	2'-3"	4'-2"
950 LBS	5'-10"	4'-4"	2'-9"	5'-2"

CAPACITY	A	B	C	D
750 LBS	4'-10"	4'-4"	2'-3"	4'-2"
950 LBS	5'-10"	4'-4"	2'-9"	5'-2"

**NOTE:**  
CONTACT CUSTOM ELEVATOR MFG. CO. FOR  
CUSTOM CAR AND HOISTWAY DIMENSIONS.

# Hoistway Size Requirements

**PLAN - E**

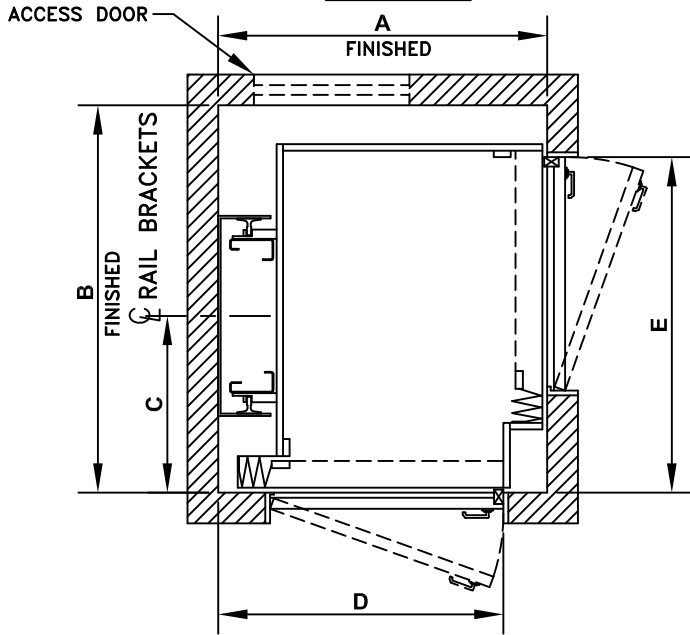

**PLAN - F**

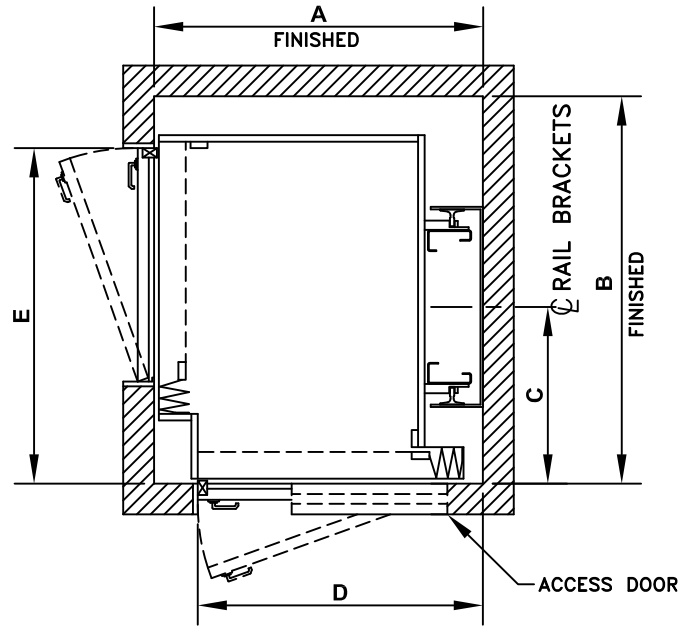

CAPACITY	A	B	C	D	E
750 LBS	4'-4"	5'-0"	2'-3 1/4"	3'-10 1/4"	4'-3 3/4"
950 LBS	4'-4"	6'-0"	2'-9 1/4"	3'-10 1/4"	5'-3 3/4"

CAPACITY	A	B	C	D	E
750 LBS	4'-4"	5'-0"	2'-3 1/4"	3'-10 1/4"	4'-3 3/4"
950 LBS	4'-4"	6'-0"	2'-9 1/4"	3'-10 1/4"	5'-3 3/4"

**PLAN - G**

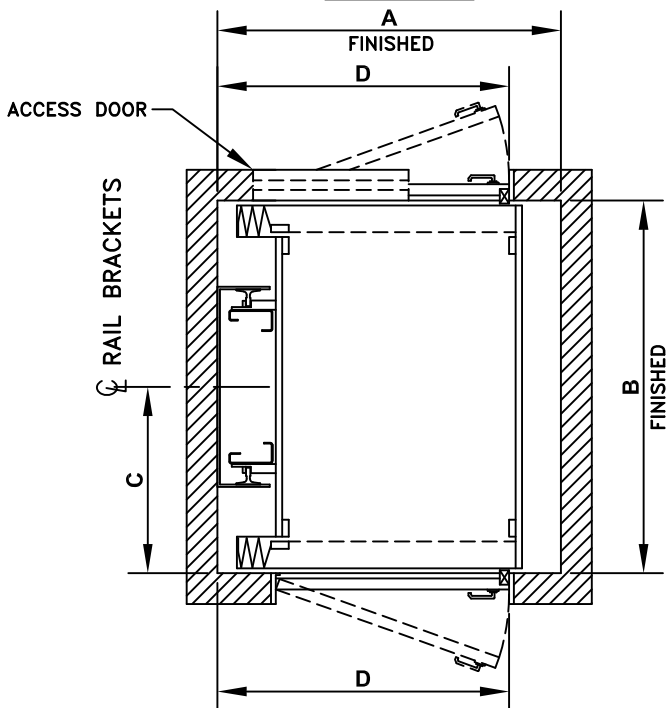

**PLAN - H**

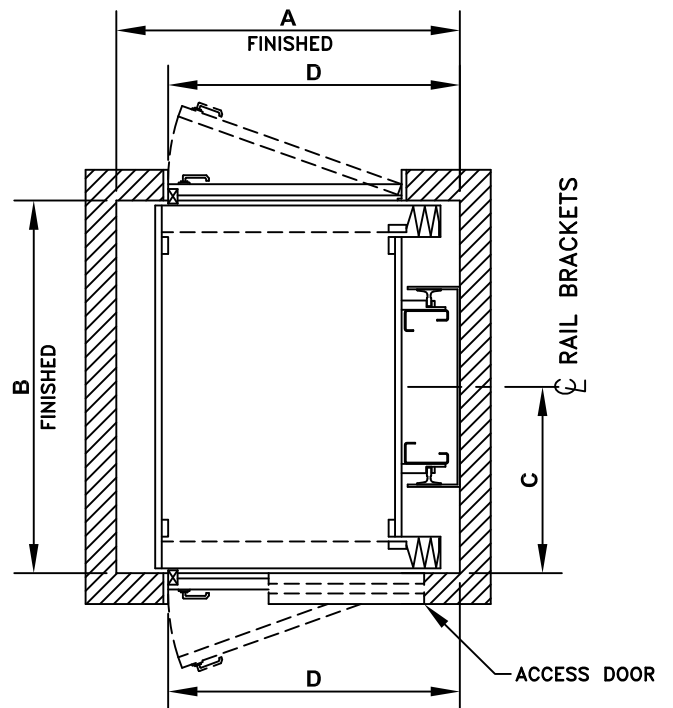

CAPACITY	A	B	C	D
750 LBS	4'-5"	4'-9 1/2"	2'-4 3/4"	3'-9"
950 LBS	4'-5"	5'-9 1/2"	2'-10 3/4"	3'-9"

CAPACITY	A	B	C	D
750 LBS	4'-5"	4'-9 1/2"	2'-4 3/4"	3'-9"
950 LBS	4'-5"	5'-9 1/2"	2'-10 3/4"	3'-9"

**NOTE:**  
CONTACT CUSTOM ELEVATOR MFG. CO. FOR  
CUSTOM CAR AND HOISTWAY DIMENSIONS.

# Recommended Hoistway Construction Plan

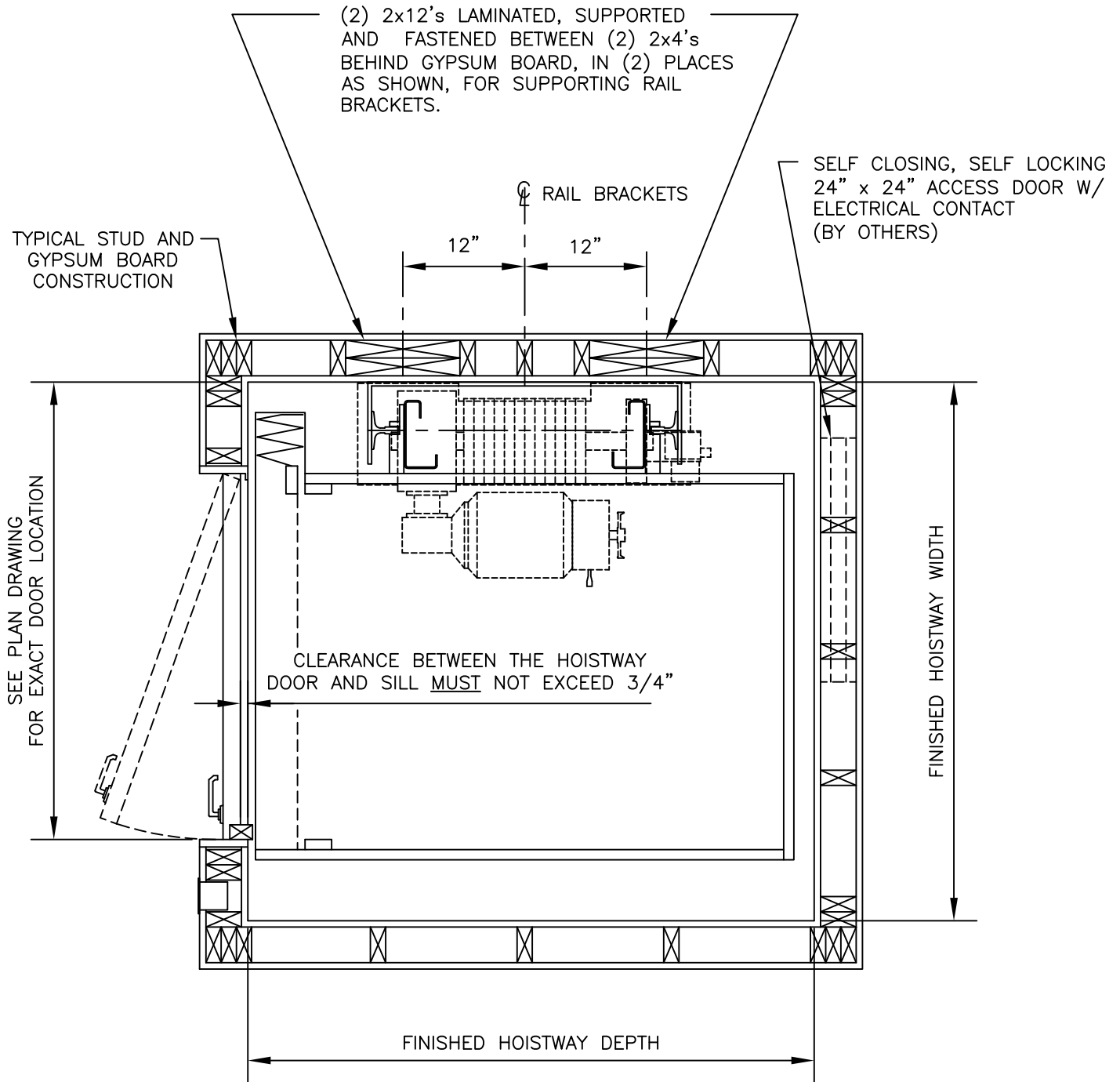

# Recommended Hoistway Construction Elevation

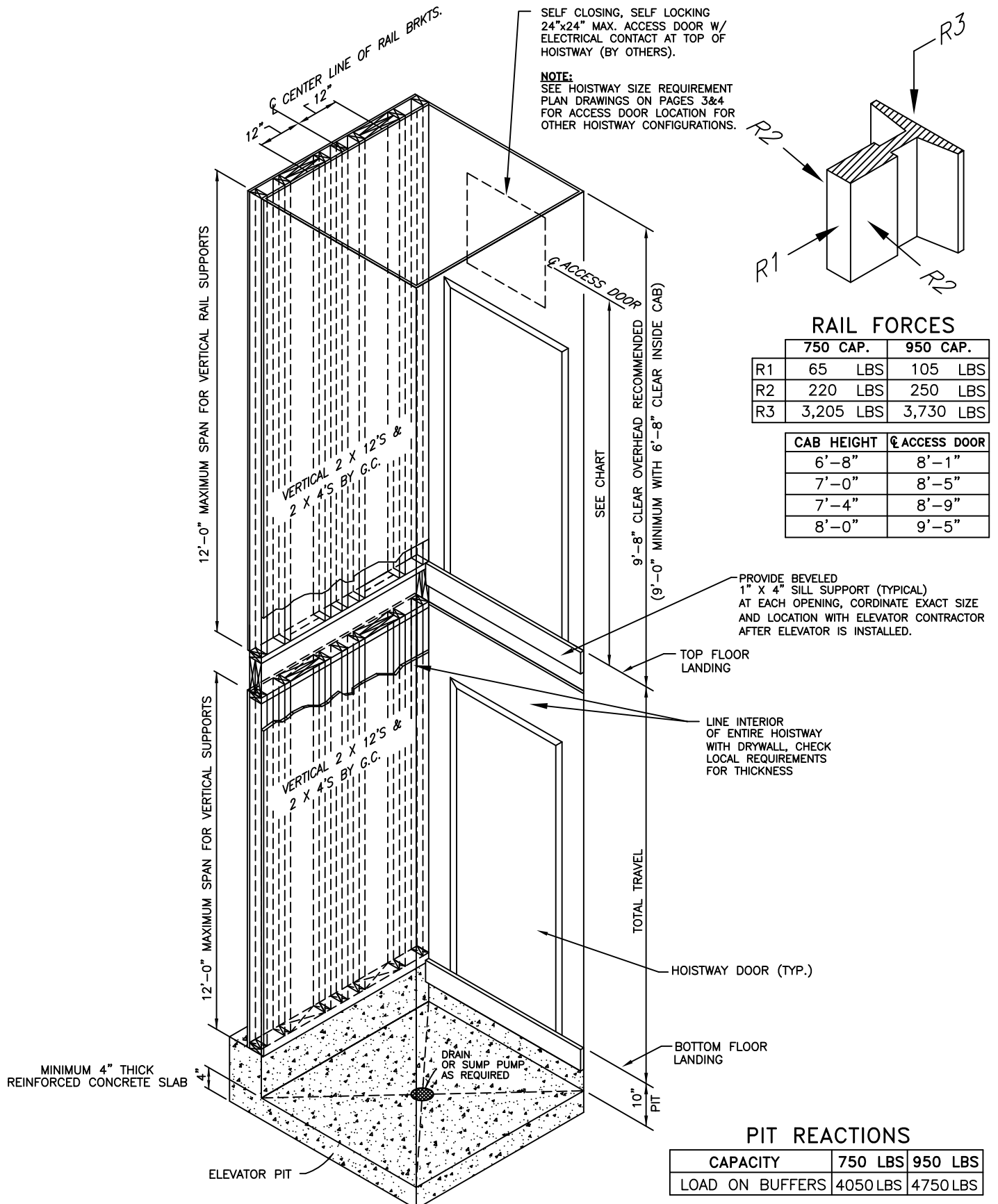

## RAIL FORCES

	750 CAP.	950 CAP.
R1	65 LBS	105 LBS
R2	220 LBS	250 LBS
R3	3,205 LBS	3,730 LBS

CAB HEIGHT	$\phi$ ACCESS DOOR
6'-8"	8'-1"
7'-0"	8'-5"
7'-4"	8'-9"
8'-0"	9'-5"

## PIT REACTIONS

CAPACITY	750 LBS	950 LBS
LOAD ON BUFFERS	4050 LBS	4750 LBS



# Control Equipment / Machine Room Plan

## TYPICAL MACHINE ROOM LAYOUT

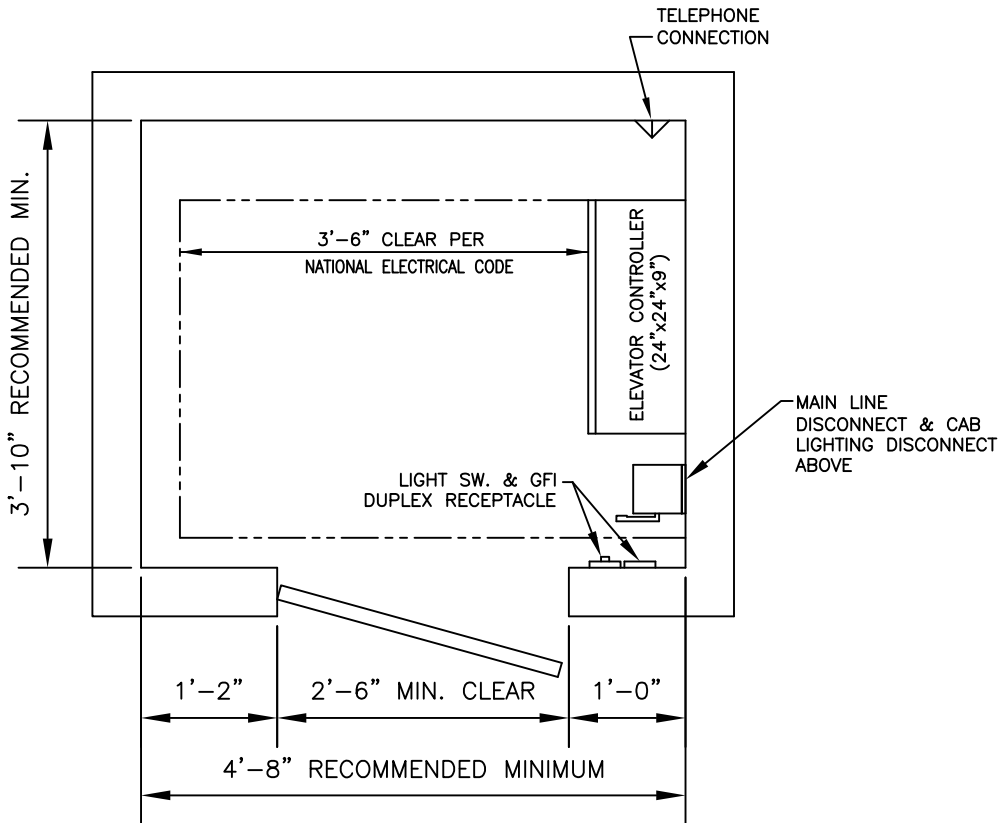

### NOTE

WHEN A SEPARATE MACHINE ROOM IN ACCORDANCE WITH NEC IS REQUIRED, IT SHALL BE CONSTRUCTED AS DETAILED. CHECK ALL STATE AND LOCAL CODE REQUIREMENTS.

### MATERIAL REQUIRED BY OTHERS:

- MAIN LINE DISCONNECT (SEE SPECIAL REQUIREMENTS)
- CAR LIGHT DISCONNECT
- LIGHT, LIGHT SWITCH, AND GFI DUPLEX RECEPTACLE
- TELEPHONE CONNECTION
- HEAT
- KNOCK-OUT BETWEEN MACHINE ROOM/CONTROLLER AND HOISTWAY
- A MINIMUM CLEARANCE OF 30" WIDE X 42" DEEP MUST BE MAINTAINED IN FRONT OF ALL ELECTRICAL EQUIPMENT
- LOCKABLE ACCESS DOOR (WHEN MACHINE ROOM PROVIDED)

SEE "WORK BY OTHERS" FOR MORE DETAILED REQUIREMENTS

## ALTERNATE MACHINE ROOM LAYOUT

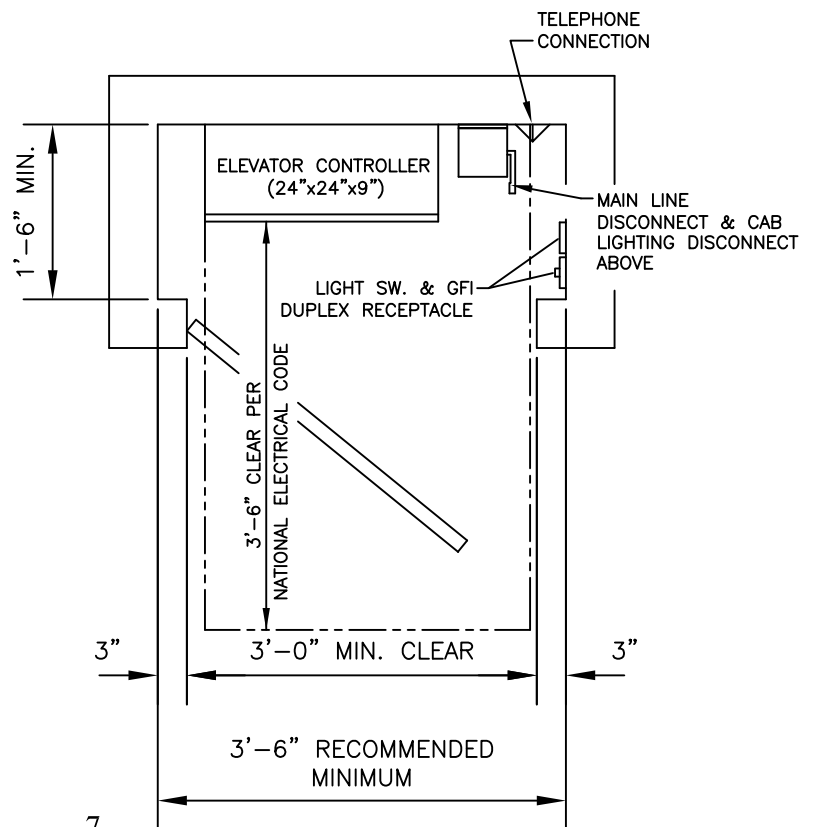

## Part 1: General

### 1.1 Description of Work

To furnish all labor and materials required to cover a complete installation of (one) overhead winding drum residential elevator. The elevator is to be installed in a first class workmanlike manner in accordance with the specifications and drawings provided.

### 1.2 Work By Others

The following preparatory work to accommodate the elevator installation is to be done by others and is part of work of other sections.

#### A. Hoistway

1. A finished plumb hoistway of proper size and construction conforming to ASME A17.1, all applicable building codes, and the elevator layout drawings.
2. Adequate supports shall be provided for fastening rail brackets as indicated on the layout drawings. Supports must withstand rail forces indicated.
3. A poured pit conforming to all applicable codes, ASME A17.1, and to the dimensions indicated on the layout drawings must be provided. The pit must be designed for the impact load indicated and must be guaranteed dry and level from wall to wall.
4. Knock-out in walls between the machine room/controller and elevator hoistway for routing electrical lines and for hall buttons shall be coordinated with the elevator contractor.
5. All wall patching, painting, and grouting by others.
6. Hoistway doors, frames, entrances, sills, and associated framing to be provided and installed by purchaser or general contractor.
7. A lockable self-closing machine/governor access door with electric contact shall be provided in accordance with layout drawing (when required).

#### B. Machine Room

1. When a separate machine room is required it shall be built to conform to the layout drawings, NFPA 70, ASME A17.1, and all applicable building code requirements. It shall have suitable access, a lockable door, a convenience outlet, and light switch. Machine room temperature must be maintained between 60 and 100 degrees Fahrenheit. Relative humidity not to exceed 95%.
2. A telephone line to the machine room and tied into the elevator controller as per ANSI/ASME A17.1 code.
3. Machine room vents as required by local code.

#### C. Electrical Requirements

1. A 220VAC, single phase service, with neutral, to a lockable safety disconnect switch, fused with time delay fuses shall be furnished in the machine room in accordance with NFPA 70. A normally open electric interlock contact is required in the switch for battery isolation.
2. A 120VAC, single phase, 15 AMP service to a lockable disconnect switch, or circuit breaker, located in the machine room shall be provided for the cab lighting in accordance with NFPA 70.

### 1.3 Quality Assurance

The elevator shall be designed, manufactured, installed, and inspected in accordance with ANSI/ASME A17.1 standards and all applicable regulations of federal, state, and local codes and ordinances as adopted by local agencies having jurisdiction.

#### A. References

1. American National Standards Institute (ANSI)
2. American Society of Mechanical Engineers (ASME)
3. National Electric Code (NFPA 70)
4. CSA B44.1/ASME A17.5, elevator and escalator electrical equipment requirements.

#### B. Qualifications

The installation shall be performed by a company with no less than (5) years of successful experience in the assembly and

erection of similar type elevators and who has adequate product liability insurance.

#### C. Regulatory Requirements

The elevator installer shall verify requirements of the local authority having jurisdiction and shall obtain and pay for necessary municipal and state permits and inspections as required, and make tests as called for by the regulations of such authorities.

## Part 2: Submittals

### 2.1 Product Data

Submit manufacturer's literature including product data, cab designs, color charts, signal fixtures, and specifications.

### 2.2 Layout Drawings

Layout drawings shall be submitted showing the general arrangement of the elevator equipment including dimensions, clearances, location of machine equipment, and all loads and reactions imposed on pit and building structure.

## Part 3: Product

### 3.1 Manufacturer

The overhead winding drum type residential elevator shall be manufactured by Custom Elevator Manufacturing Co. Inc. Plumsteadville, PA. U.S.A. Toll Free 1-888-443-2800 or 215-766-3380 Fax 215-766-3385 and installed by \_\_\_\_\_

### 3.2 Characteristics

**Type:** Overhead Winding Drum  
**Capacity:** 750 lbs.  
**Car Speed:** 40 FPM  
**Operation:** SAPB/single button collective  
**Travel:**  
**Number of Stops:**  
**Number of Openings:**  
**Inside Car Dimensions:** 36" X 48" X 80" high  
**Power Supply:** 220 Volt, single phase, 60 Hz.  
**Cab Design:**  
**Push Button Faceplates and Handrail Finish:**

### 3.3 Equipment

#### A. Operation

Operation of the elevator shall be single automatic push button or single button collective (field programmable); momentary pressure on any button will call or send the elevator to the corresponding landing providing all doors are closed.

1. **Battery lowering:** In the event of a power failure, the elevator shall automatically stop, and then descend to the next lowest landing while monitoring all safety circuits. If the elevator is equipped with a power car door(s) option, the car door(s) shall open and close automatically. Batteries are to have an automatic charging system.
2. **Emergency car lighting:** In the event of a power failure, the car lights shall automatically transfer to battery power.
3. **Homepark feature:** The elevator shall automatically return to a field programmable designated landing after one minute without use.
4. **Automatic two-way leveling:** The leveling device shall automatically stop and maintain the car within ½ inch of the landing regardless of the change in load.
5. **Protection Run Timer:** An internal run timer that will cause the car to stop and hold if the elevator should fail to reach a landing within a pre-determined time.

## B. Control System

A microprocessor based control system certified and labeled to the requirements of CAN/CSA-B44.1/ASME A17.5 shall be provided. It shall include a motor starter with a potential relay, motor overload device, variable voltage variable frequency (VVVF) motor speed control, an uninterrupted power supply with battery charging circuit, and external relay redundancy circuits to prevent dangerous conditions as a result of a single contact failure. All circuits shall be fuse protected. All to be enclosed in a single NEMA 1 lockable cabinet.

## C. Machine Limit

In addition to the normal car stopping devices, top and bottom normal limit switches, top final limit switch and slack cable switch, the driving machine will be fitted with a rotary limit switch that includes (2) independently operated contacts that are designed to disconnect power to the driving machine in the event that the car over-travels the top or bottom landing.

## D. Overspeed Governor

An overspeed governor shall be provided in the overhead and a tension weight with idler sheave shall be located in the pit. The governor cable shall be 1/4" dia. 8x19 traction steel and attach to the car safety device. The governor shall be designed to activate the car safeties in the event of an overspeed in the down direction. Governor shall be self resetting and be provided with means to seal the tripping speed adjustment.

## E. Driving Machine

The driving machine shall be located at the top of the elevator hoistway. It shall include a two-stage ring and worm gear reducer, inverter controlled flange mounted motor, a spring applied and electrically released disc brake assembly with manual release handle, a drum with accurately machined grooves to guide and support the hoist cables, an outboard pillow block bearing to support the drum shaft, a manual lowering hand wheel, and an emergency stop switch all to be mounted on a structural steel base. Elastomeric sound absorbing isolation mounts shall be furnished between the machine base and its mounting.

## F. Car Frame and Platform

The car frame shall be fabricated from structural and formed steel members, welded and bolted construction, of the cantilevered design. It shall be fitted with roller guide shoes, car safeties, and a slack cable switch that will disconnect power to the machine if a rope should become slack or broken. The car platform shall be fabricated from 1-1/4" plywood protected with a fire retardant material.

## G. Car Suspension

The elevator car frame shall be suspended by (2) 3/8" diameter, 8 X 19, traction steel cables. Cables shall attach to the car safety device with approved type wedge sockets.

## H. Guide Rails

The car guide rails shall consist of (2) machined steel "tee" sections, no less than 8 lb. per foot, securely fastened to the hoistway structure with steel brackets. All rail end sections shall be tongue & groove type joined with steel splice plates.

## I. Car Operating Panel

Car operating panel shall consist of metal lens call push buttons with red LED halo lighting for each landing, an alarm button, emergency stop button, light switch, and a digital car position indicator with car direction arrows all mounted onto a brushed stainless steel faceplate (brass optional). Digital C.P.I. shall be field programmable.

## J. Landing Controls

Landing control stations shall consist of a metal lens call button and a "car here" indicator with red LED halo lighting mounted onto a brushed stainless steel faceplate (brass optional).

## K. Hoistway Doors

The general contractor or owner is to furnish (elevator contractor may opt to furnish) and install hoistway doors, frames, hinges, and passage sets at each landing. The type and installation of the doors and frames must comply with ASME A17.1, all state and local codes and as per manufacturer's layout drawings.

### 1. Door locks

An approved/certified electro-mechanical unit system contact and lock shall be furnished for each hoistway entrance. The interlock device shall prevent elevator operation unless all doors are closed and locked and prevent opening of a door when the car is not at that landing.

## L. Car Door(s)

The car door(s) shall be solid panel construction accordion type folding door(s) that prevent a person's hands or feet from extending through openings. Finish shall be vinyl laminate chosen from the manufacturer's standard color selections (hardwood, visifold, and aluminum optional). Car door shall be equipped with an approved/certified positive contact switch to prevent elevator operation with the car door(s) open (power car door(s) optional).

## M. Car Enclosure

The cab walls shall be constructed of 3/4" minimum plywood substrates faced with plastic laminate or wood veneers with wood trim accents as selected from the manufacturer's standard designs. A brushed stainless steel handrail (brass optional) shall be located on one wall. A telephone shall be furnished in the elevator cab for emergency communication. Cab ceiling shall be a minimum of 3/4" thick substrate with at least a (2) bulb light fixture as selected from the manufacturer's standard ceiling designs. Finished flooring covering is to be furnished by others.

## N. Electrical Wiring

All wiring and electrical materials shall conform to NFPA 70 and with all applicable codes. Insulated wiring shall have flame-retardant and moisture proof outer covering and shall be run in conduit or electrical wireways as required. Traveling cables shall be flexible and suitably suspended to relieve strain.

## Part 4: Execution

### 4.1 Examination

Elevator installer shall verify dimensions of hoistway, pit, machine room, and inspect conditions of supports and structure prior to installation.

### 4.2 Installation

The elevator shall be installed in accordance with the manufacturer's instructions and shall conform to ASME A17.1, and all state and local code requirements.

### 4.3 Operating Instructions

Upon completion of the installation, the owner shall be instructed on the elevator's operation, safety precautions, and maintenance requirements. The owner shall be supplied with an owner's manual to retain for reference.

### 4.4 Maintenance

The elevator shall be maintained in accordance with the manufacturer's recommendations and all applicable codes

### 4.5 Warranty

The elevator shall have a (2) year limited parts warranty.