

**SECTION A-A**

**HOISTWAY DOOR & FRAME DETAIL FOR ASME A17.1 CODE COMPLIANT RESIDENTIAL ELEVATOR APPLICATIONS**

**Custom Elevator Mfg. Co., Inc.**  
 5191 Stump Road  
 Plumsteadville, PA 18949  
 Toll Free: 888-443-2800  
 Fax: 215-766-3385

*Custom*  
**ELEVATOR**  
 manufacturing  
 company, Inc.

**ROPED HYDRAULIC  
 RESIDENTIAL ELEVATOR**

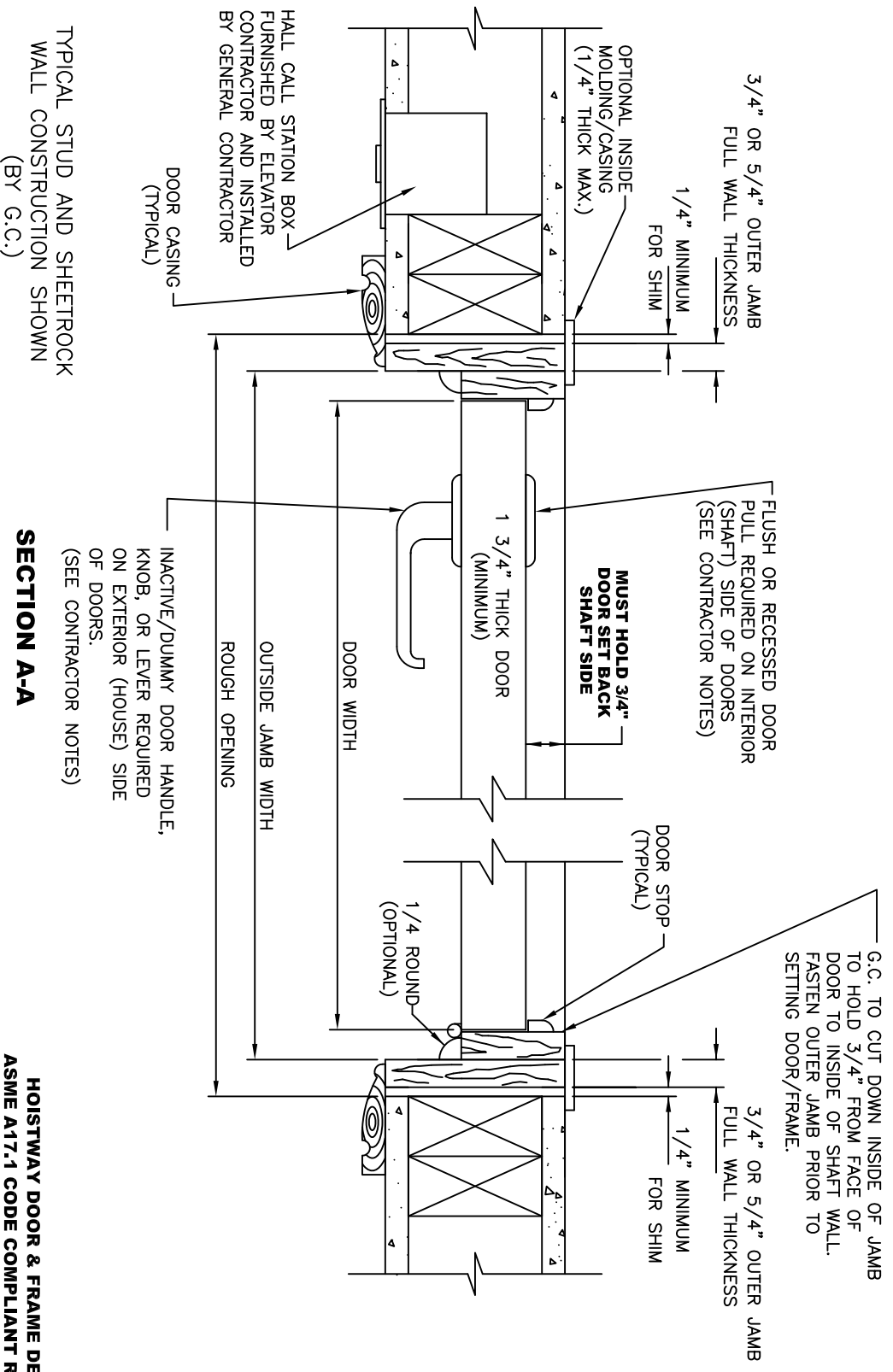

LEFT HAND SHOWN  
RIGHT HAND OPPOSITE

TYPICAL STUD AND SHEETROCK  
WALL CONSTRUCTION SHOWN  
(BY G.C.)

INACTIVE/DUMMY DOOR HANDLE,  
KNOB, OR LEVER REQUIRED  
ON EXTERIOR (HOUSE) SIDE  
OF DOORS.  
(SEE CONTRACTOR NOTES)

**SECTION A-A**

**HOISTWAY DOOR & FRAME DETAIL FOR  
ASME A17.1 CODE COMPLIANT RESIDENTIAL  
ELEVATOR APPLICATIONS**

**Custom**  
**ELEVATOR**  
manufacturing  
company, Inc.

Custom Elevator Mfg. Co., Inc.  
5191 Stump Road  
Plumsteadville, PA 18949  
Toll Free: 888-443-2800  
Fax: 215-766-3385

**ROPED HYDRAULIC  
RESIDENTIAL ELEVATOR**

**RECOMMENDED DOOR HARDWARE  
(FURNISHED BY GENERAL CONTRACTOR)**

Hinges: (3) 4" x 4" full mortise hinges [at least (1) hinge is to be spring hinge].

Recommended Source:

Standard Hinge: Hoyer Co. part# BB1279

Spring Hinge: Bommer Ind. part# LB4310C-400

**Door Handles:** Flush or recessed door pulls are required on the interior (shaft side) of doors. Hardware is not to project more than 1" from face of door. Inactive/dummy door handle, knob, or lever required on exterior (house side) of doors.

Recommended Source (shaft side):

Baldwin #0395 ring pull or similar

**Latch:** Adjustable roller latch with 2 3/4" x 1 1/8" T-strike.

Recommended Source:

Rockwood Roller Latch-#592

or Hoyer Co. Roller Latch-#318D

**CONTRACTOR NOTES:**

1. KILN DRIED SOLID CORE WOOD DOORS/FRAMES TO BE PROVIDED AND INSTALLED BY THE GENERAL CONTRACTOR. DOOR CLOSERS OR SPRING LOADED HINGES ARE REQUIRED. SEE DETAILS.
2. CLEARANCE BETWEEN THE HOISTWAY DOOR AND SILL MUST BE HELD AT 3/4" PER ASME A17.1-2016. NO DEVIATIONS.
3. ALL DOOR FRAMES MUST BE SET SQUARE AND PLUMB. AVOID DOORS DRAGGING AGAINST FRAME.
4. DOORS/FRAMES MUST BE SET PERFECTLY PLUMB AND INLINE WITH ONE ANOTHER FROM FLOOR TO FLOOR. PLUMB LINES MUST BE USED WHEN SETTING DOORS/FRAMES.
5. HOISTWAY DOORS ARE TO BE MARKED OUT BY ELEVATOR CONTRACTOR THEN NOTCHED/CUT-OUT BY GENERAL CONTRACTOR TO ACCEPT ELEVATOR DOOR LOOK FURNISHED BY ELEVATOR CONTRACTOR.

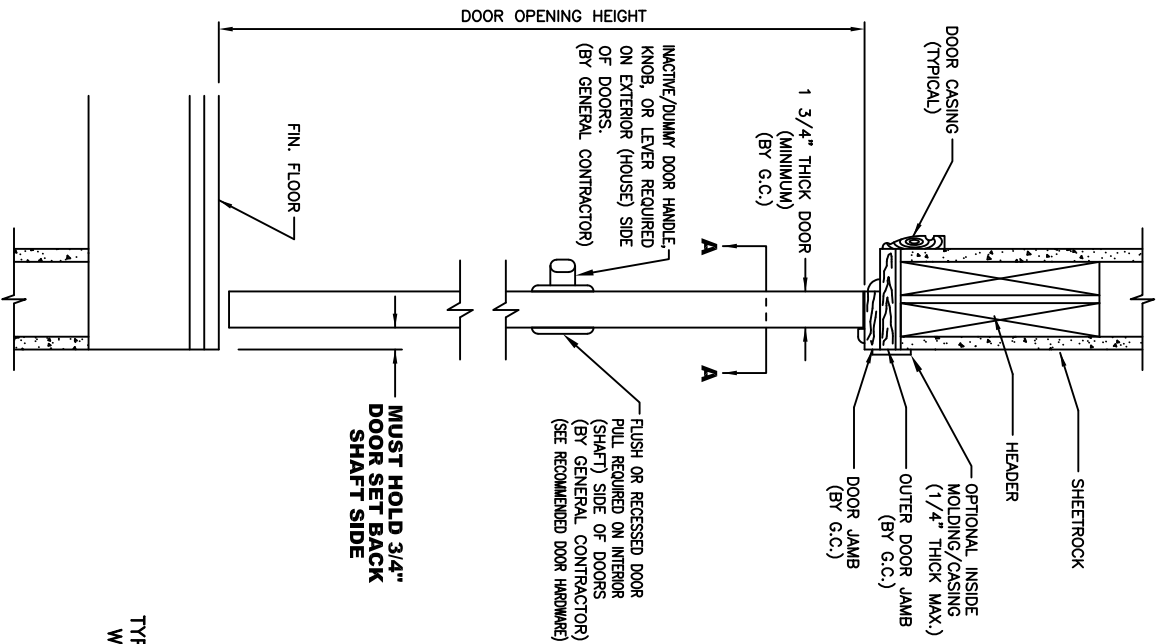

**MUST HOLD 3/4\"/>**

FLUSH OR RECESSED DOOR PULL REQUIRED ON INTERIOR (SHAFT) SIDE OF DOORS (BY GENERAL CONTRACTOR) (SEE RECOMMENDED DOOR HARDWARE)

TYPICAL STUD AND SHEETROCK WALL CONSTRUCTION SHOWN (BY G.C.)

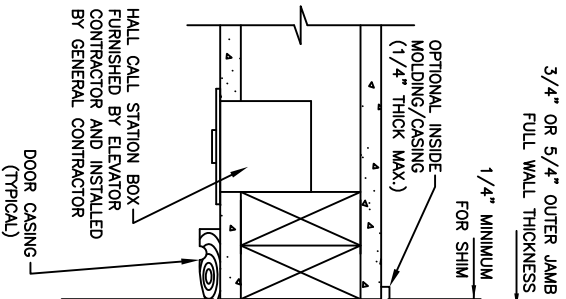

DOOR CASING (TYPICAL)

LEFT HAND SHOWN  
RIGHT HAND OPPOSITE

**SECTION A-A**

INACTIVE/DUMMY DOOR HANDLE, KNOB, OR LEVER REQUIRED ON EXTERIOR (HOUSE) SIDE OF DOORS.  
(BY GENERAL CONTRACTOR)

**HOISTWAY DOOR & FRAME DETAIL FOR ASME A17.1 CODE COMPLIANT RESIDENTIAL ELEVATOR APPLICATIONS**

**Custom ELEVATOR**  
manufacturing  
company, Inc.

Custom Elevator Mfg. Co., Inc.  
5191 Stump Road  
Plumsteadville, PA 18949  
Toll Free: 888-443-2800  
Fax: 215-766-3385

**ROPED HYDRAULIC  
RESIDENTIAL ELEVATOR**